

INSTALLATION INSTRUCTIONS

Power Steering Kit for Honda Pioneer 700

Item	Description	Item	Description
A	Motor Mount	D	Upper Shaft
B	Support Plate	E	Lower Shaft
C	ECU Plate	F	Connectors Kit

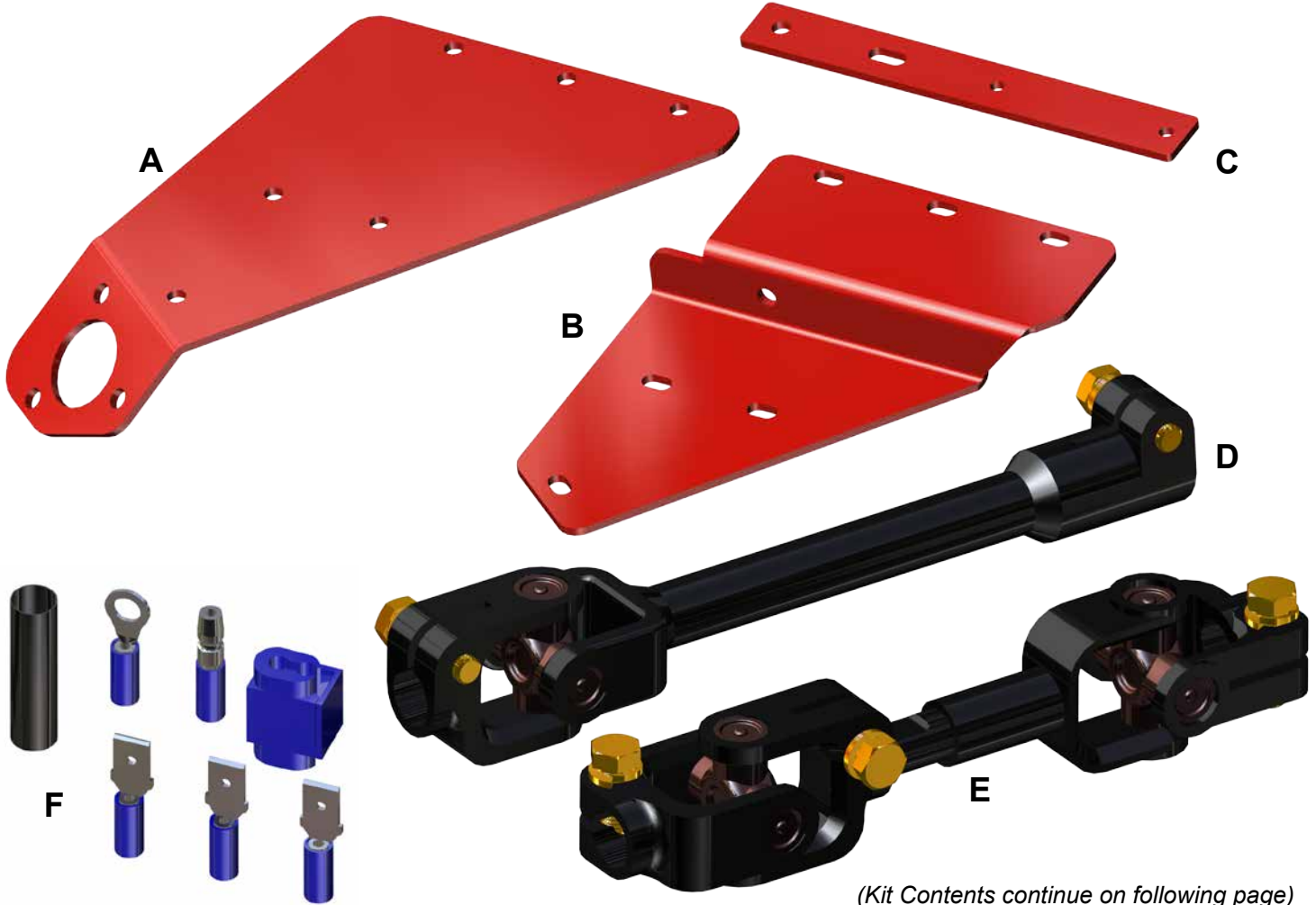

(Kit Contents continue on following page)

Read instructions and view illustrations before beginning.

Need help with your installation?



sales@superatv.com



www.superatv.com



1-812-574-7777



8:00am - 9:00pm EST M-Th
8:00am - 7:00pm EST Friday
9:00am - 2:00pm EST Saturday

*Thank You
For Choosing*

Liability Statement

SuperATV's® products are designed to best fit user's ATV/UTV under stock conditions. Adding, modifying, or fabricating any factory or aftermarket parts will void any warranty provided by SuperATV® and is not recommended. SuperATV's® products could interfere with other aftermarket accessories. If user has aftermarket products on machine, contact SuperATV® to verify that they will work together.

Although SuperATV® has thousands of satisfied customers, user should be aware that installing lift kits, long travel, or suspension kits, tires, etc. will change the ride of machine and may increase maintenance and part wear. Operating any off-road machine while, or after, consuming alcohol and/or drugs increases risk of bodily harm or death. No warranty or representation is made as to this product's ability to protect user from severe injury or death. SuperATV® urges operators and occupants to wear a helmet and appropriate riding gear at all times.

By purchasing and installing SuperATV® products, user agrees that should damages occur, SuperATV® will not be held responsible for loss of time, use, labor fees, replacement parts, or freight charges. SuperATV®, nor any 3rd party, will not be held responsible for any direct, indirect, incidental, special, or consequential damages that result from any product purchased from SuperATV®. The total liability of seller to user for all damages, losses, and causes of action, if any, shall not exceed the total purchase price paid for the product that gave rise to the claim.

SuperATV® will warranty only parts provided by SuperATV®. Any damage or problems with OEM housings, bearings, seals, or other manufacturers' products will not be covered by SuperATV®. SuperATV® parts and products are not warranted if item was not installed properly, misused, or modified.

(Kit Contents continued)

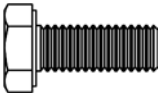
2x  **M6 x 16mm Lg. HHCS**
-includes washers (not shown)

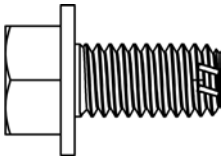
1x  **3/8\"**

3x  **M8-1.25 x 20mm Lg. FHCS**

7x  **M8-1.25 Nylock Nut**

4x  **M8-1.25 x 30mm Lg. FHCS**

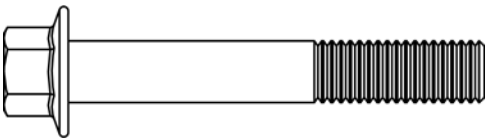
3x  **M8-1.25 x 55mm Lg. FHCS**

Item	Description	Qty
G	ECU	1
H	Motor	1
J	Wire Harness	1

*Connections

- Before installing, ensure that all Gaskets in electrical connections are properly seated.
- If Gaskets are not seated use a Flathead Screwdriver to seat.

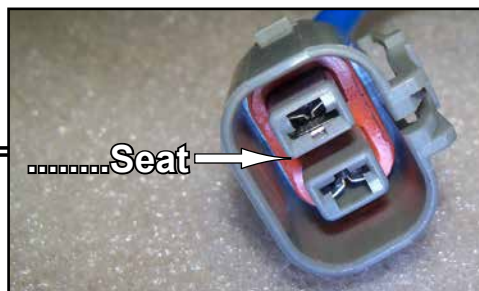
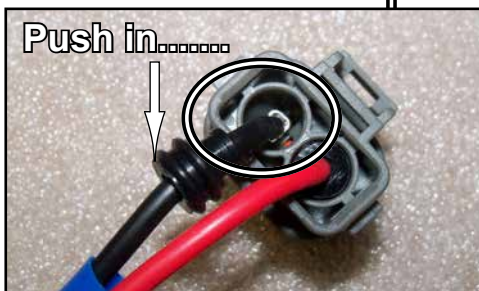
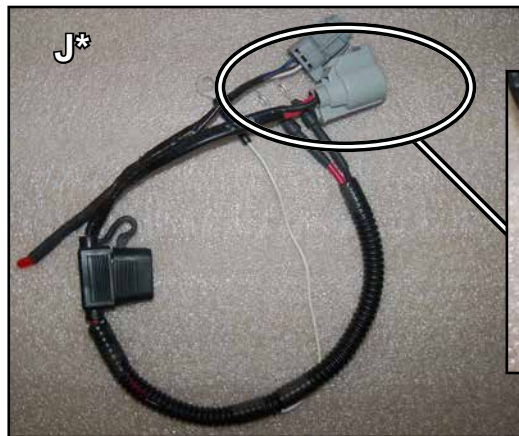
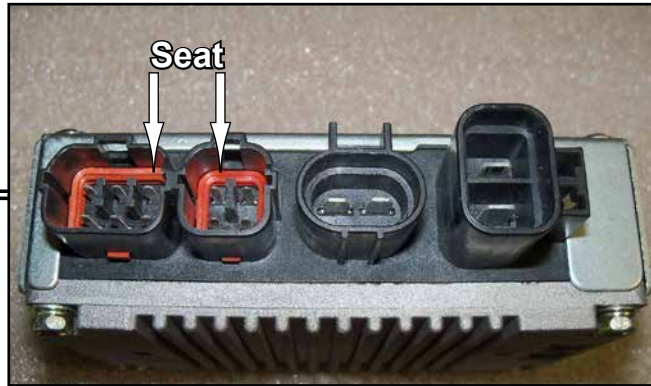

Reference only; do not assemble at this time.

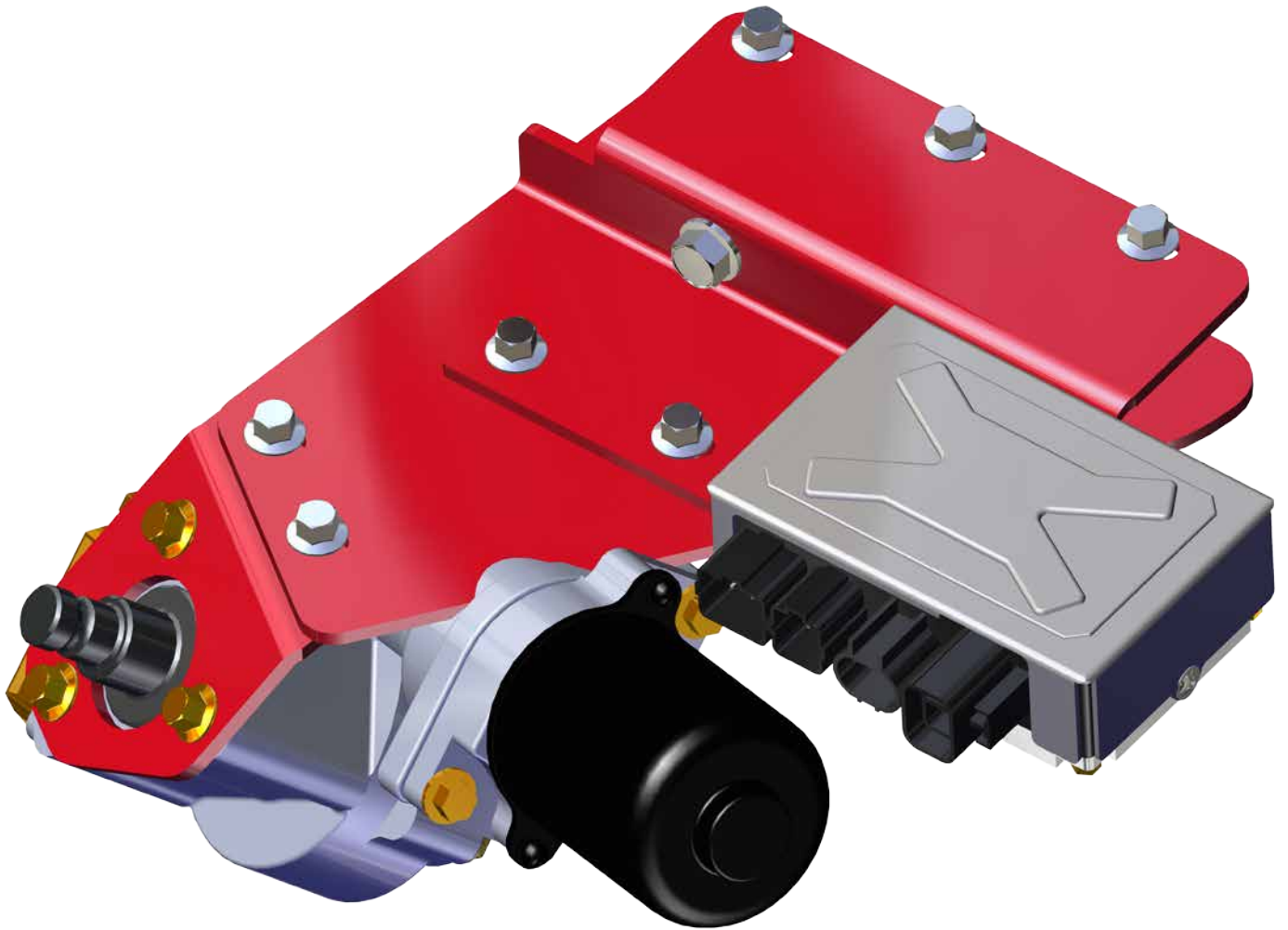

Removal: *Keep all components removed from machine.*

1. Remove Hood, Driver Side Fender, Steering Wheel, and Dash. See Figs. 1 - 1a.
2. Remove Steering Shaft from Rack and Pinion. See Fig. 2.
3. Slide Boot away from Tube and remove C-Clip from Steering Stem. Remove Steering Stem from Steering Shaft. See Fig. 2a.
 - Remove Steering Shaft from machine.
4. Remove "hump" located around Brake Pedal from Firewall. See Figs. 3 - 3a.



(removal illustrations continue on following pages)

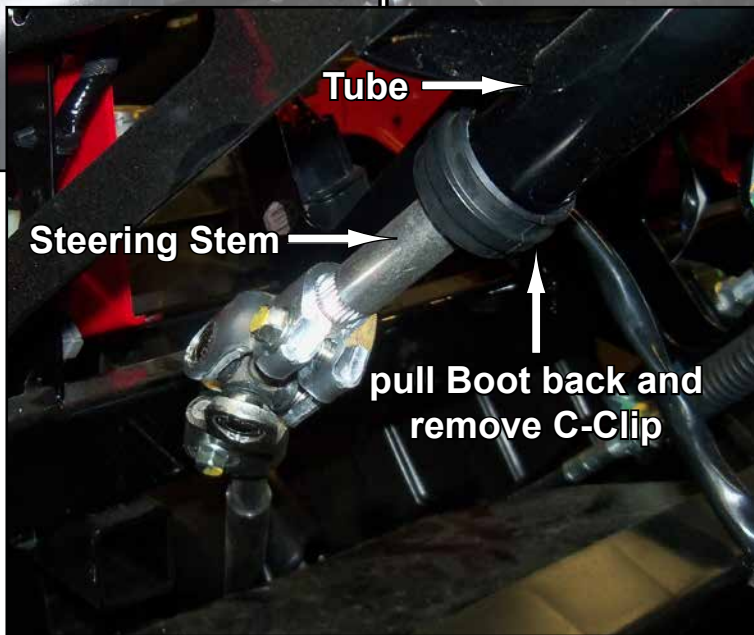
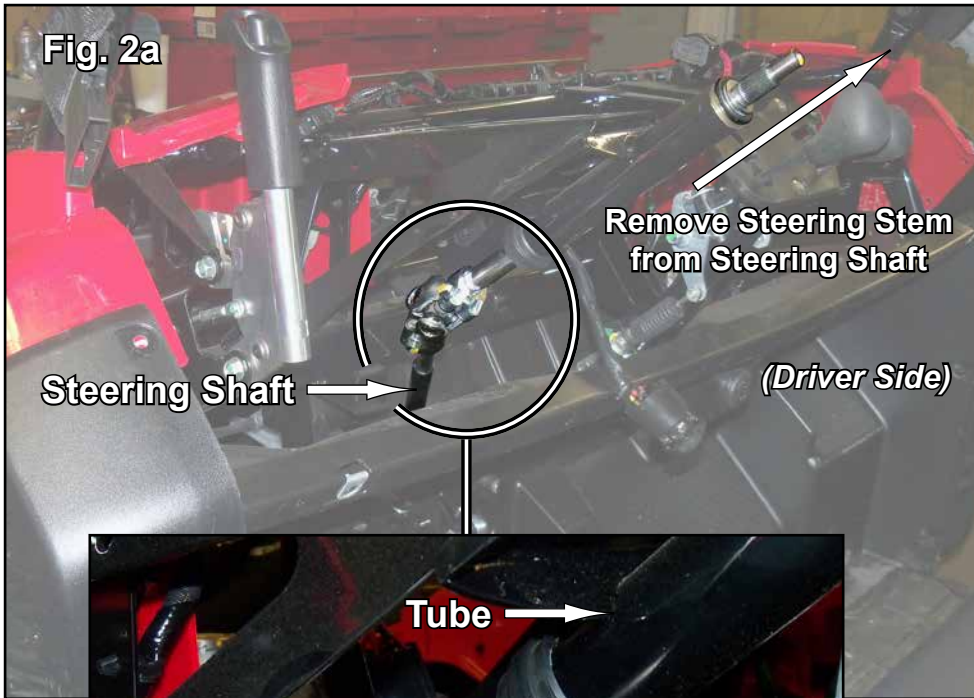
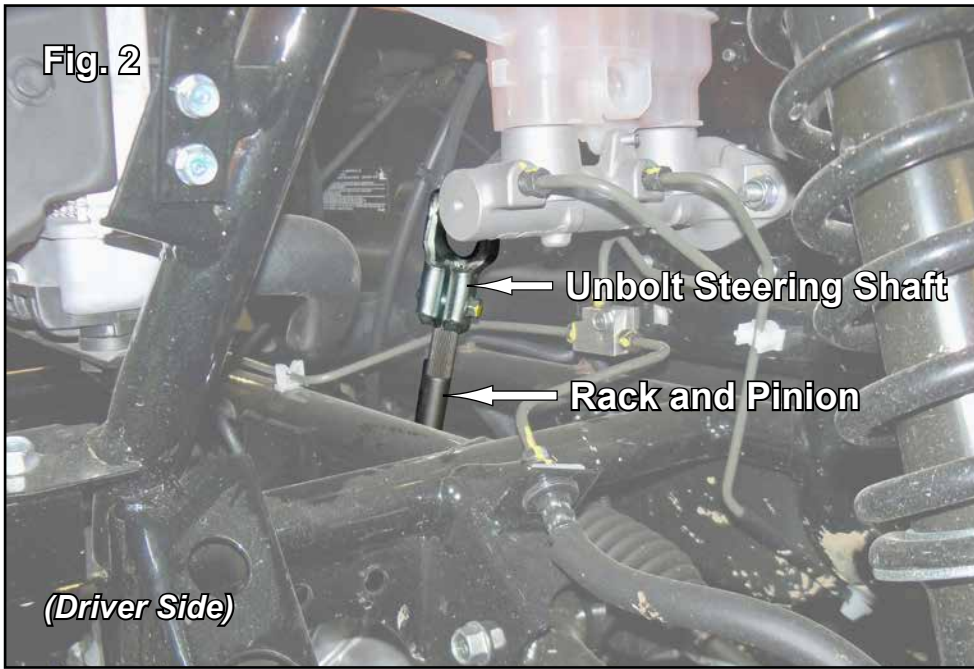

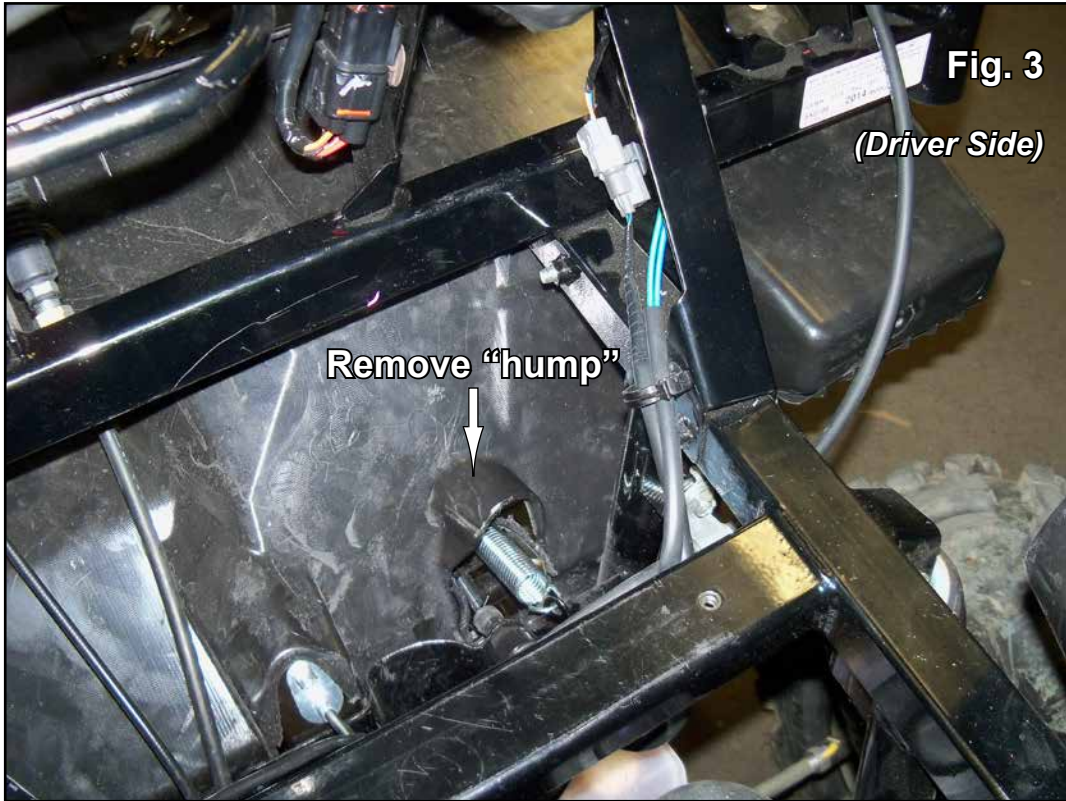

Installation: *Do not tighten hardware completely unless noted.*

1. Install ECU (G) to ECU Plate (C) with M6-1.0 x 16mm Lg. HHCS and set aside. See Fig. 1.
2. Install Lower Shaft (E) to Rack and Pinion with provided hardware. See Fig. 2.
3. Install Motor Mount (A) to Motor (H) with M8-1.25 x 20mm Lg. FHCS. See Fig. 3.
 - Install to Lower Shaft (E) with provided hardware. See Motor Shafts Detail and Fig. 4.
4. Install Upper Shaft (D) to stock Steering Stem with provided hardware. Ensure that stock C-Clip and Boot are reinstalled at this time. See Figs. 5 - 5d.
5. Install Support Plate (B) to Motor Mount (A) with M8-1.25 x 20mm Lg. FHCS and M8-1.25 Nylock Nuts. See Figs. 6 - 6a.
6. Secure Support Plate (B) and Motor Mount (A) with M8-1.25 x 50mm Lg. FHCS and M8-1.25 Nylock Nuts. See Fig. 7.
 - Install ECU (G) and ECU Plate (C) assembly to Support Plate (B) and Motor Mount (A) assembly with M8-1.25 x 30mm Lg. FHCS. See Fig. 7.
7. Secure Support Plate (B) to stock hole in Frame with 3/8"-16 x 3/4" Lg. Self Tap. See Figs. 8 - 8a.
8. Slightly trim stock plastic to clear Support Plate (B). See Fig. 9.
9. Plug Wiring Harness (J) into ECU (G). See "Wiring Details" at end of installation instructions.
10. Ensure no components are binding, rubbing, or causing interference and tighten all hardware completely.

Fig. 1

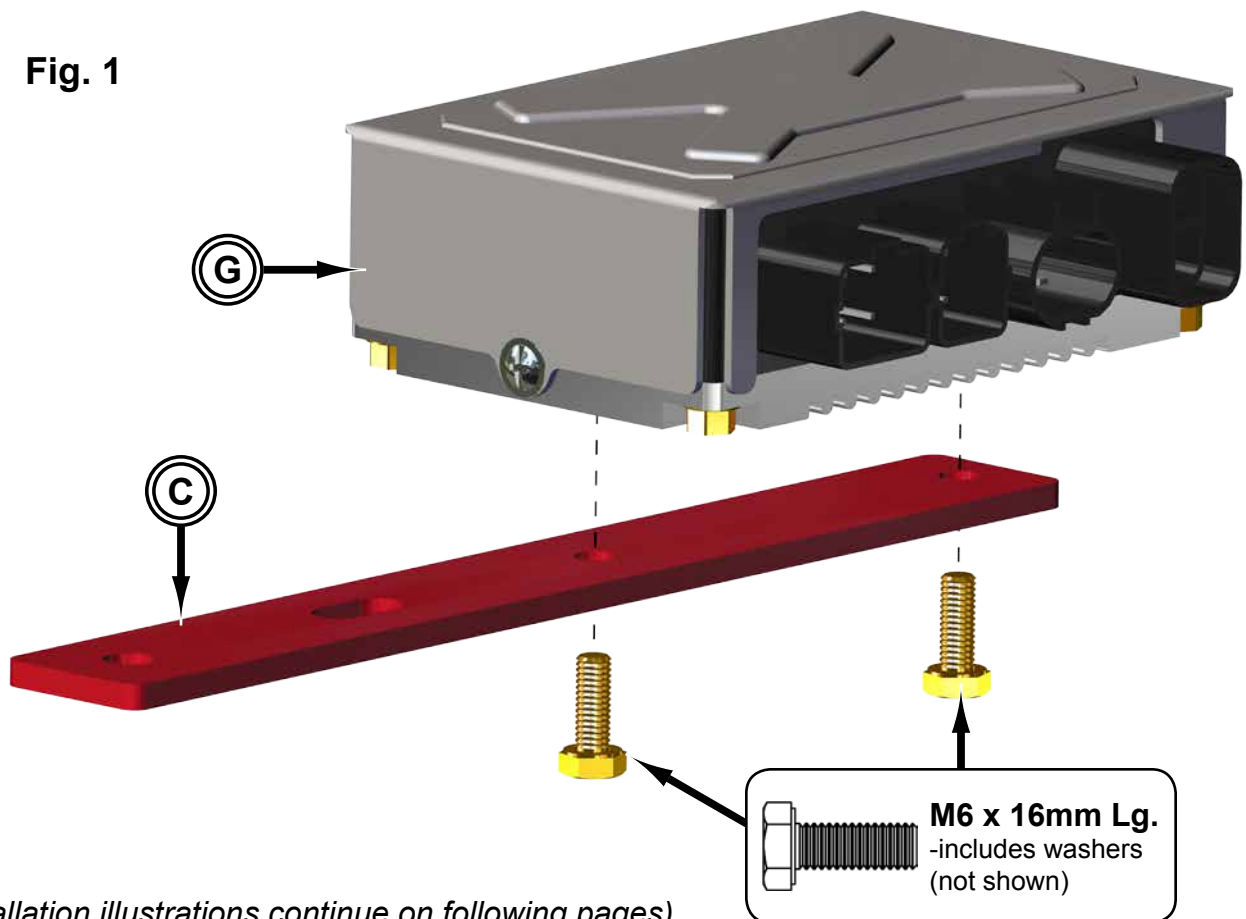

(installation illustrations continue on following pages)

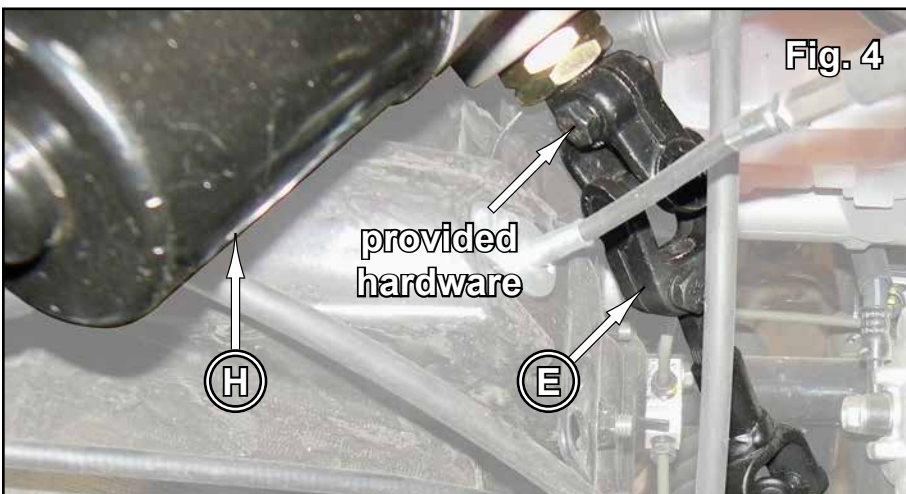
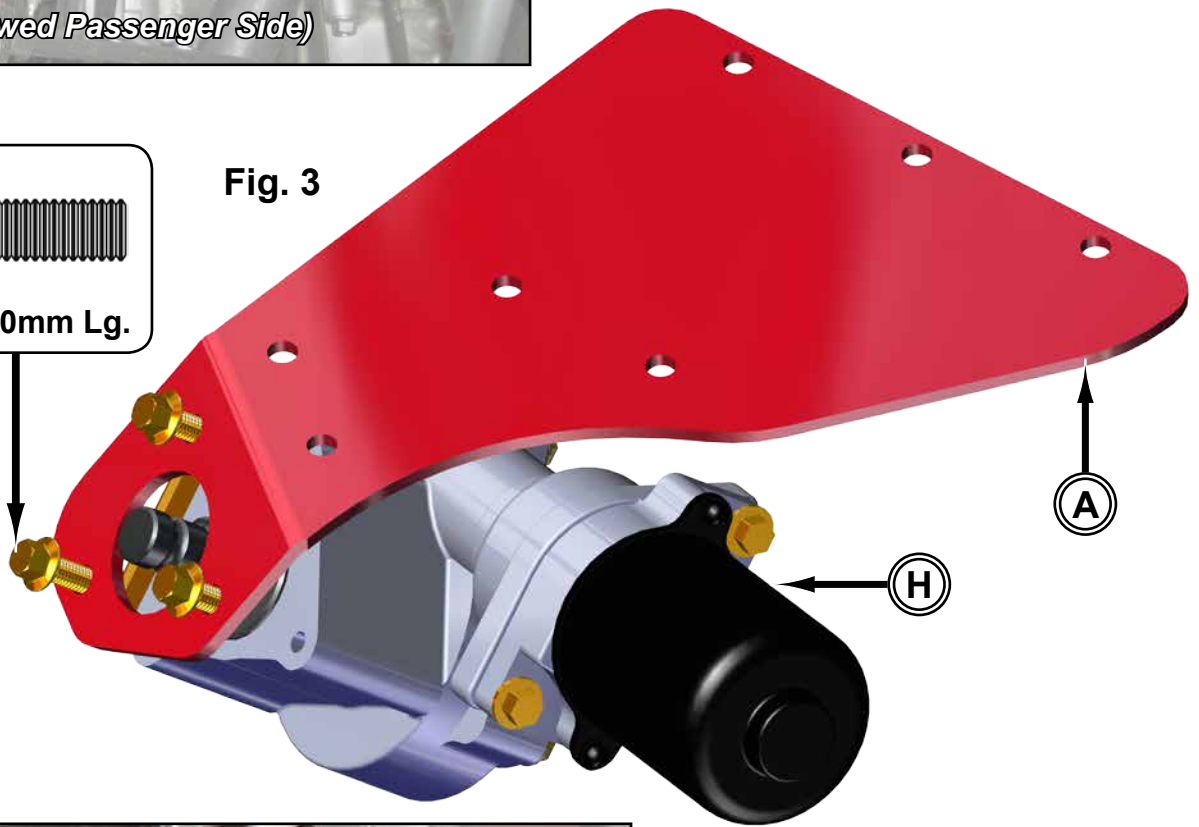
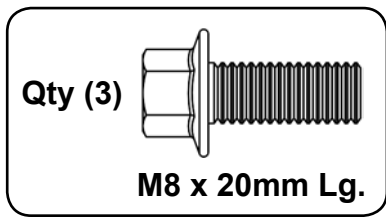
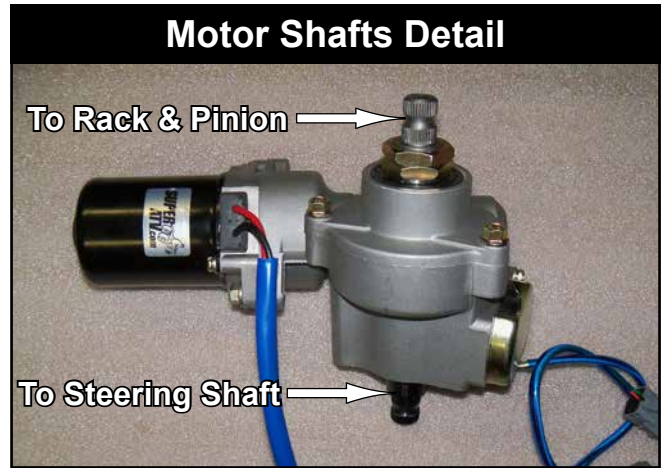
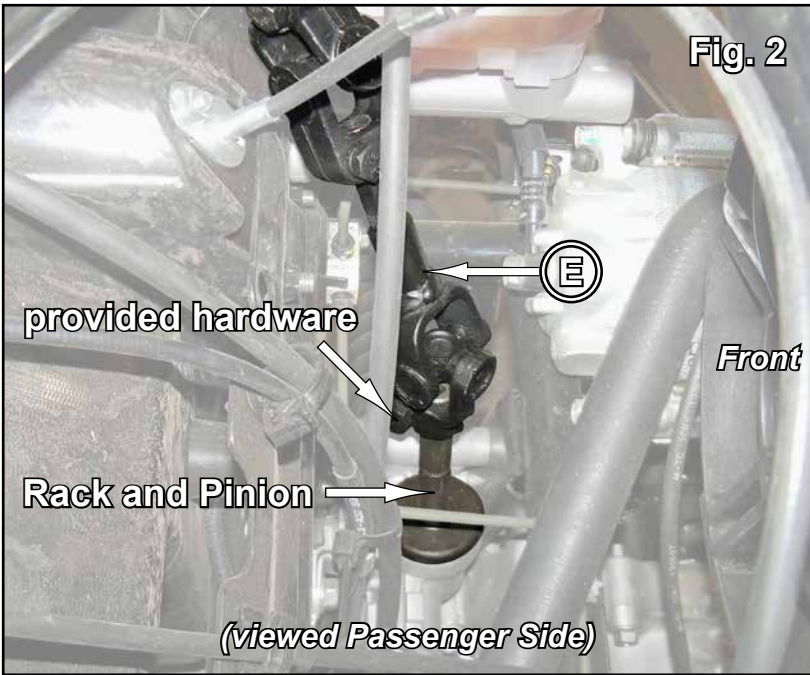

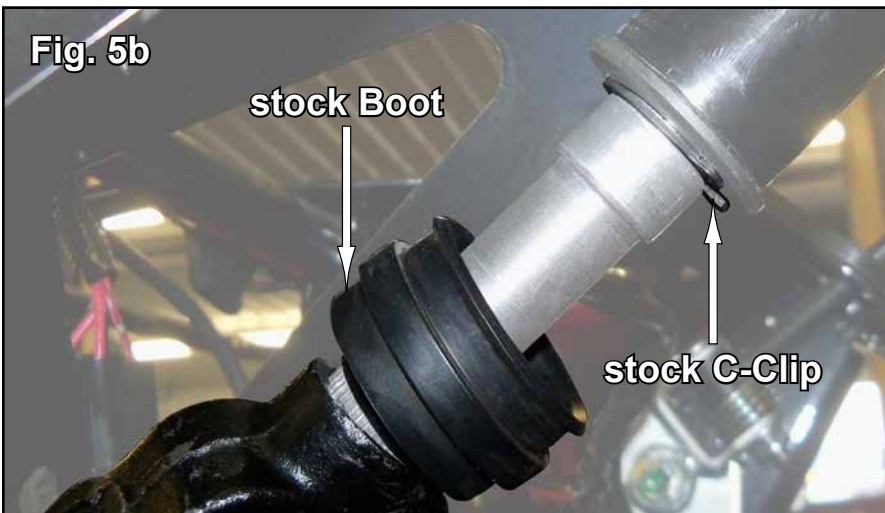
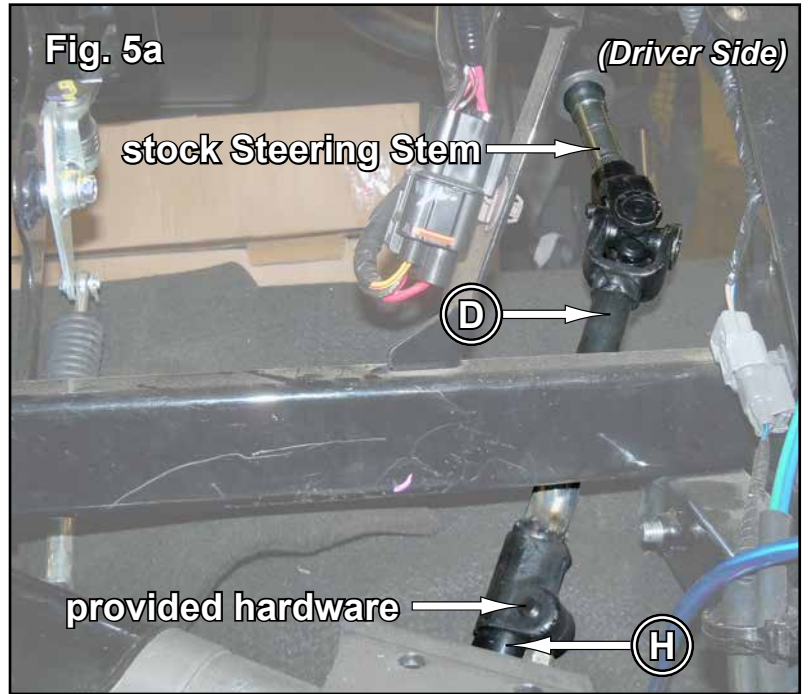

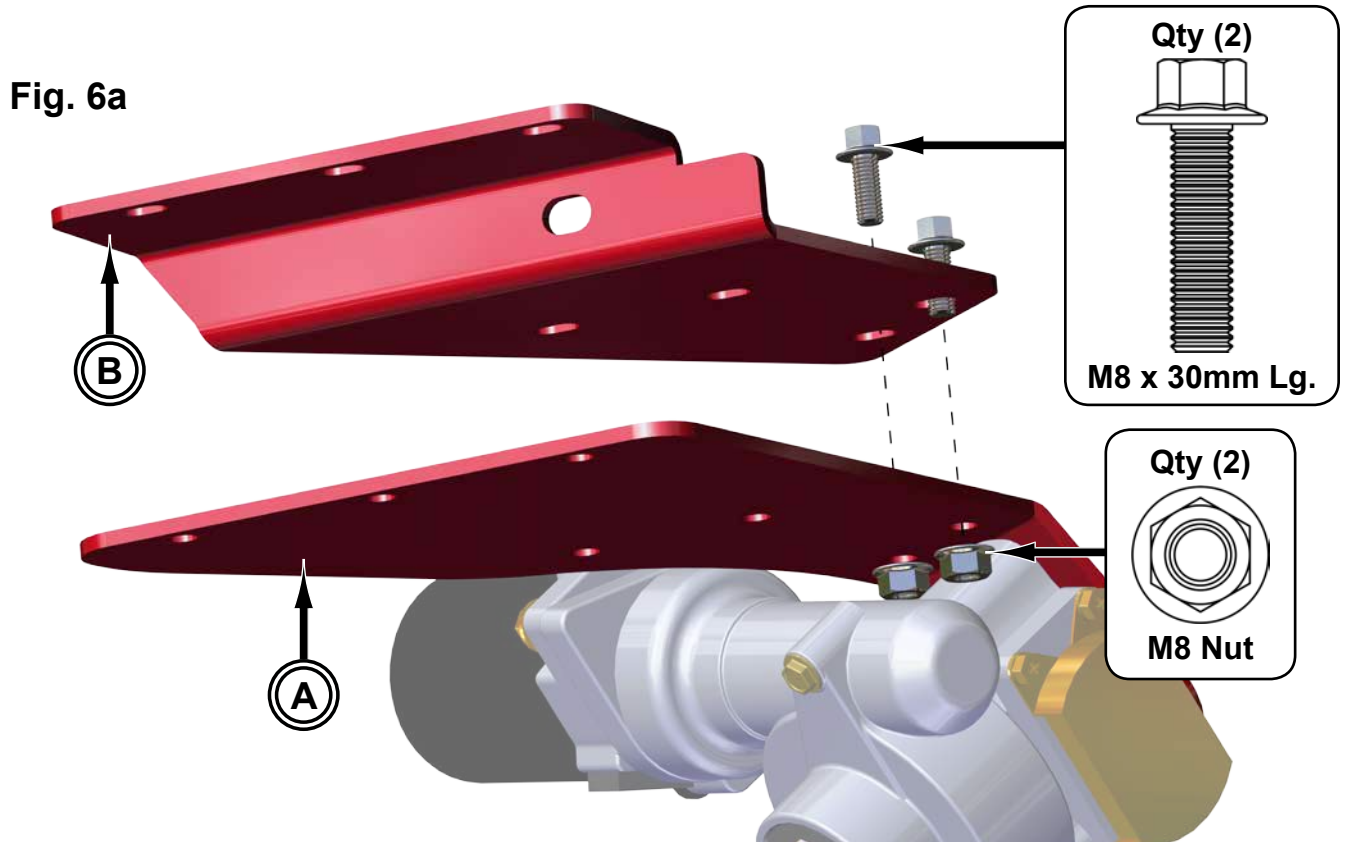
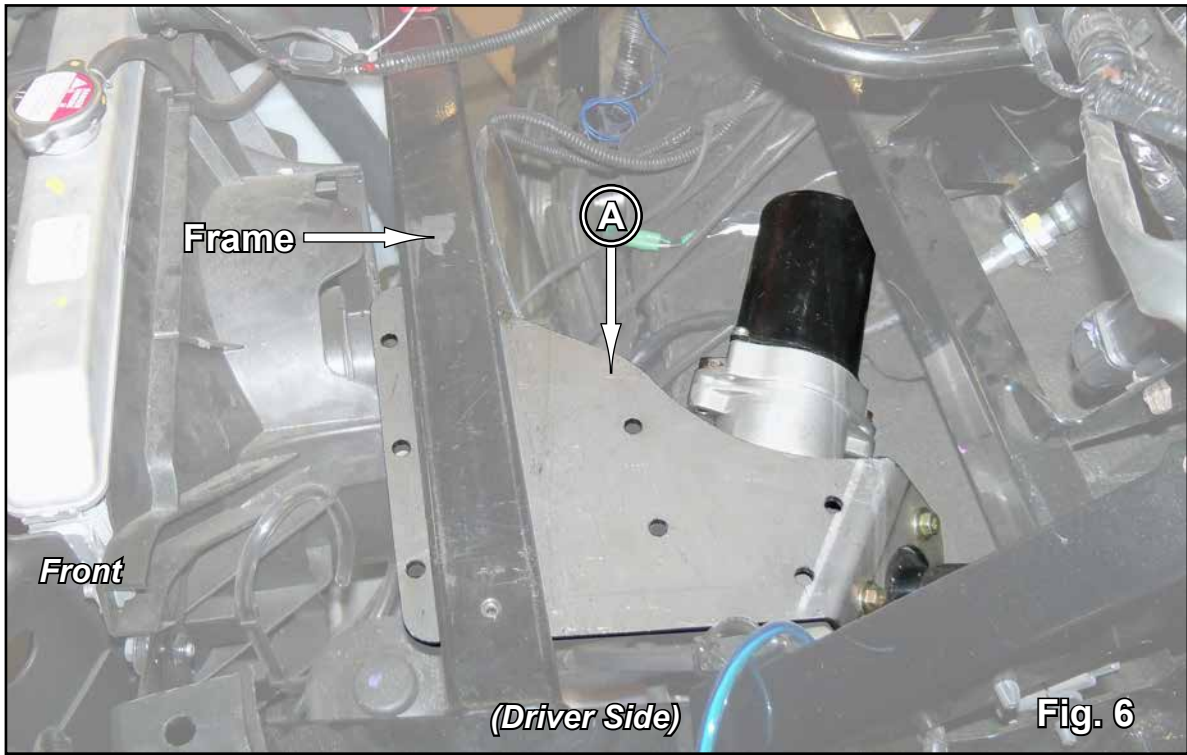

Fig. 7

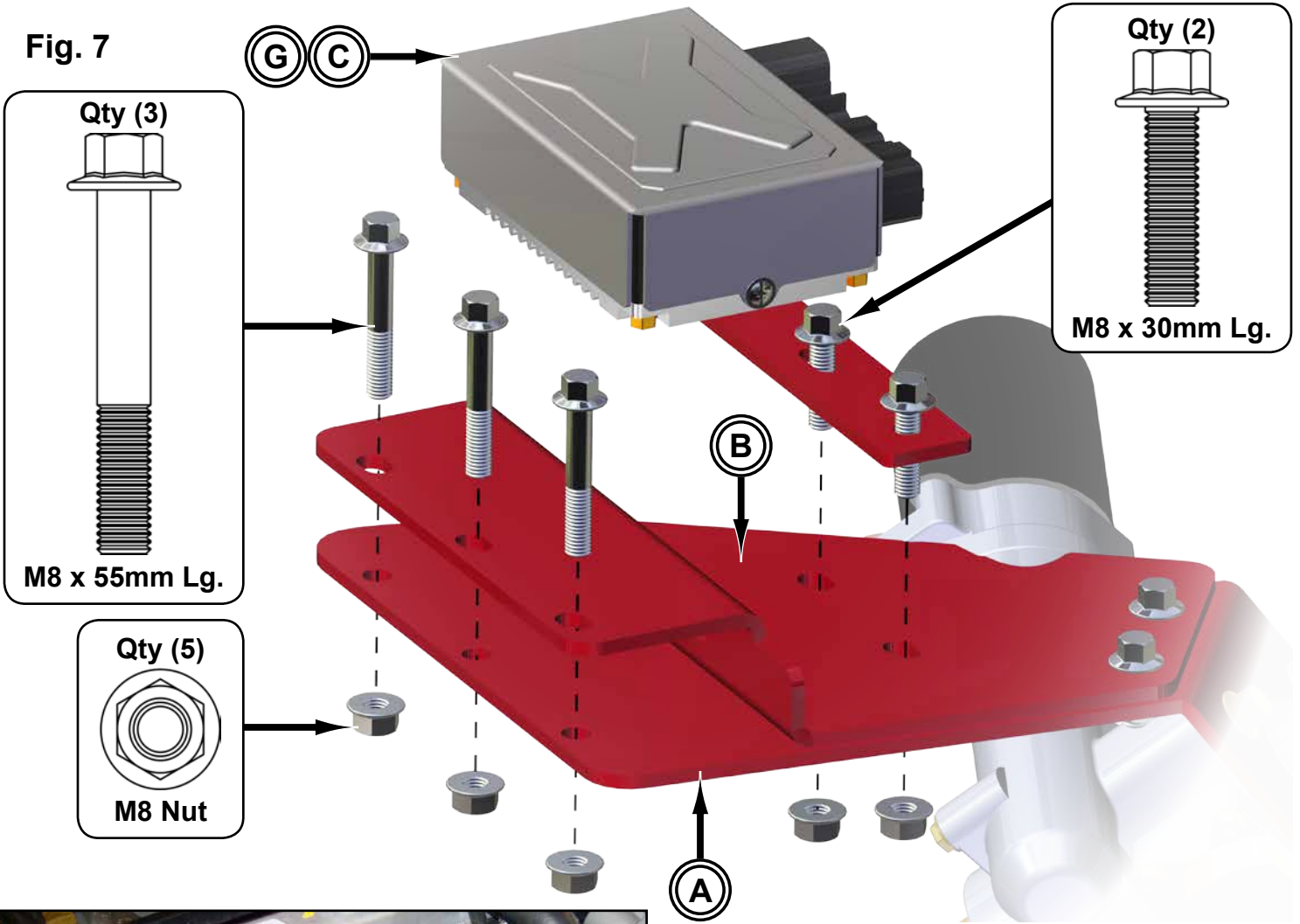

Fig. 8

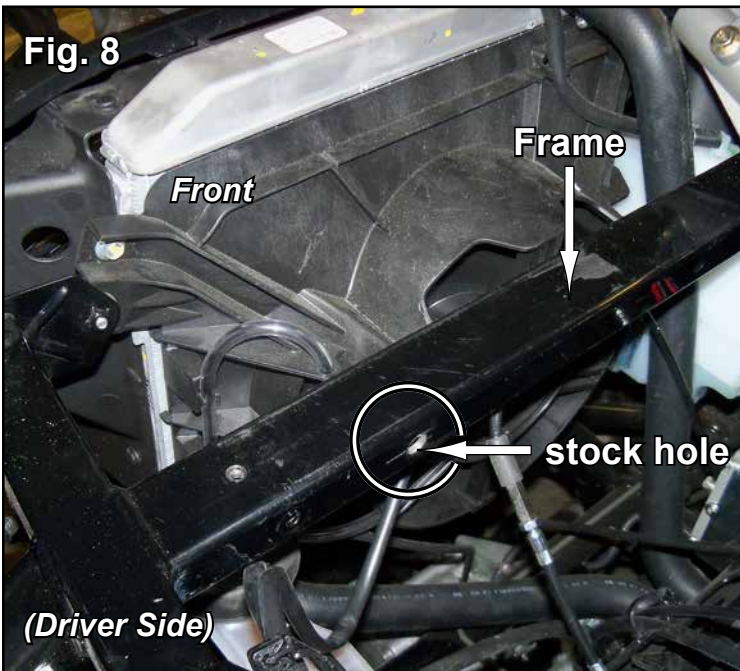

Fig. 8a

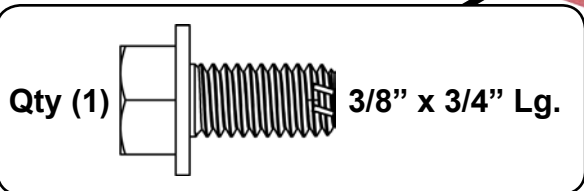
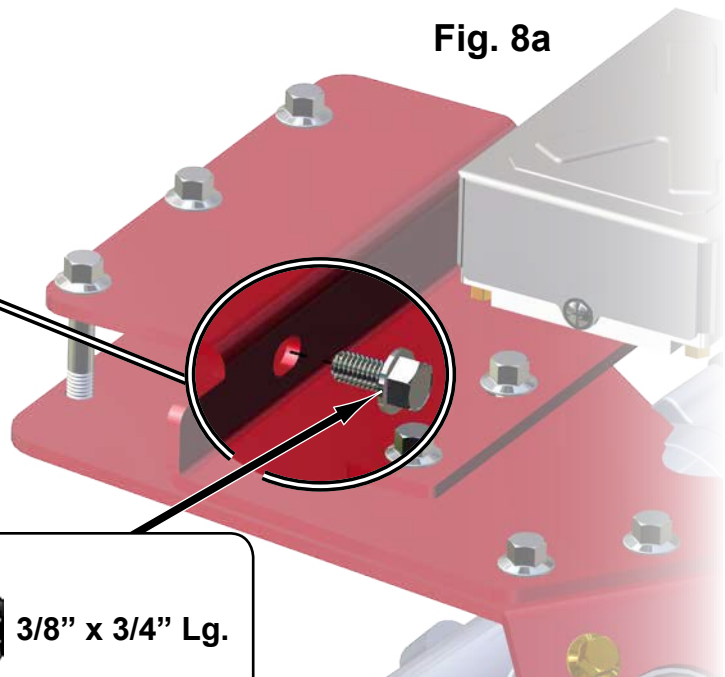

Fig. 9

(Driver Side)

trim stock plastic to clear
Support Plate (B)

(B)

Front

Complete

(Driver Side)

Front

Wiring Details



Plug	Function
A	Torque Sensor
B	Switched 12V Source
C	Power
D	Motor

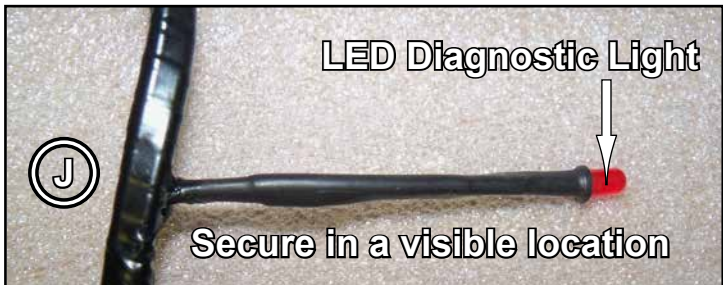
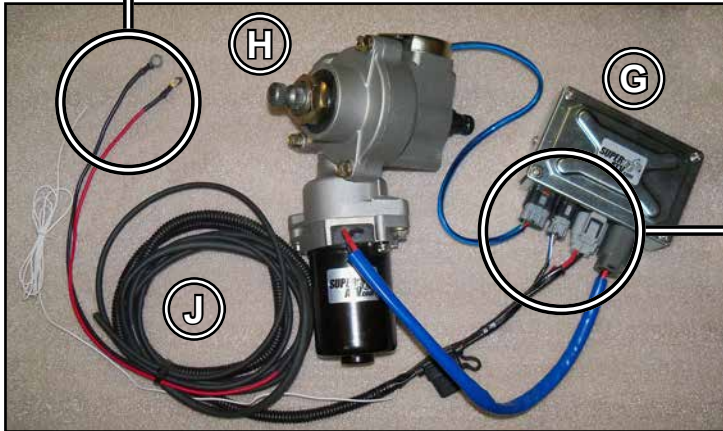

When activated, LED Diagnostic Light will flash once for about 1 second before turning off indicating proper function. Should different patterns occur, contact SuperATV.

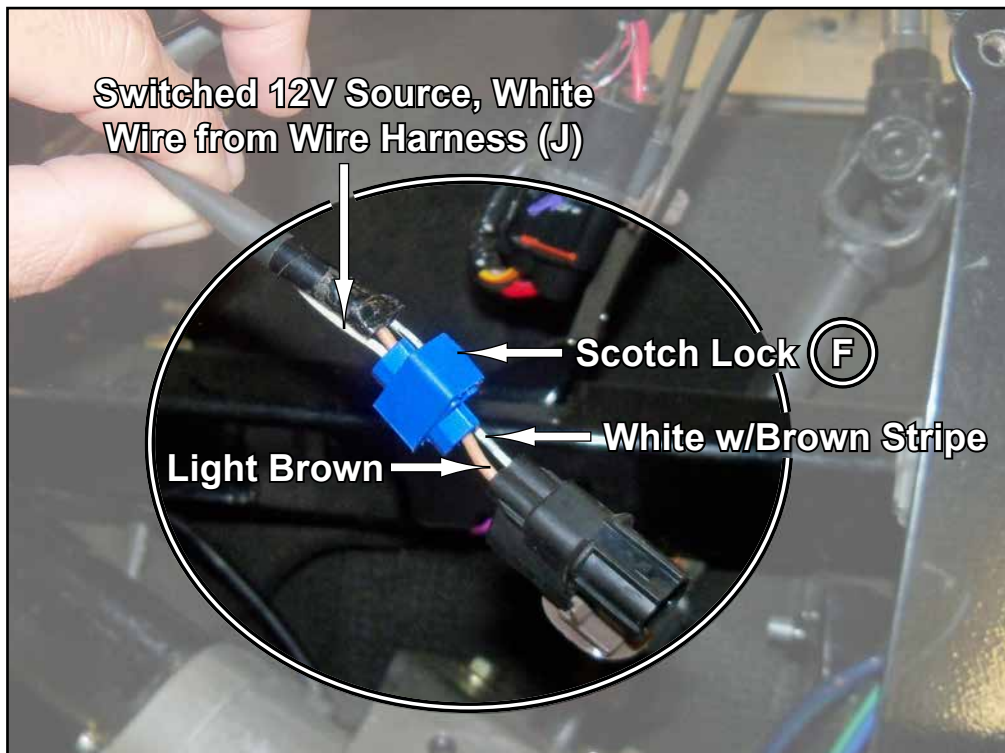

(Wiring Details continued)

